

2023 Full Year Results Presentation

12 March 2024



Disclaimer

This presentation contains certain forward-looking statements with respect to the financial condition, results of operations and business of TI Fluid Systems plc (the “Company”). The words “believe”, “expect”, “anticipate”, “intend”, “estimate”, “forecast”, “project”, “will”, “may”, “should” and similar expressions identify forward-looking statements. Others can be identified from the context in which they are made. By their nature, forward-looking statements involve risks and uncertainties, and such forward-looking statements are made only as of the date of this presentation. Accordingly, no assurance can be given that the forward-looking statements will prove to be accurate, and you are cautioned not to place undue reliance on forward-looking statements due to the inherent uncertainty therein. Past performance of the Company cannot be relied on as a guide to future performance. Nothing in this presentation should be construed as a profit forecast. The financial information in this presentation does not contain sufficient detail to allow a full understanding of the results of the Company. For more detailed information, please see the Company’s published financial data at [tifluidsystems.com](https://www.tifluidsystems.com)



Agenda

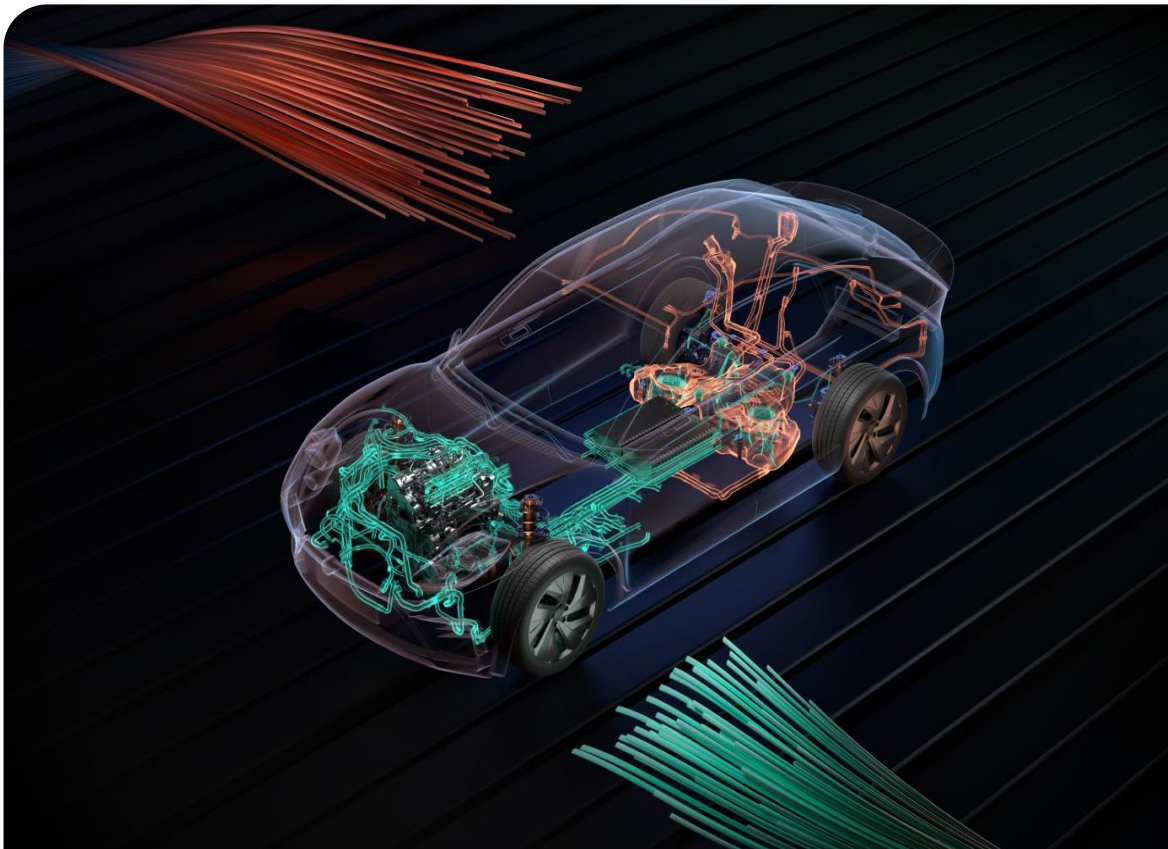

- ① 2023 Highlights
- ② 2023 Financials & 2024 Outlook
- ③ Strategic Progress

01

2023 Highlights



Hans Dieltjens

Chief Executive Officer & President

Delivering on our commitments

<p>1</p> <p>Strong financial performance</p>	<p>2</p> <p>Bookings underpin transition to EVs</p>	<p>3</p> <p>Enhancing our position in China</p>	<p>4</p> <p>Capital allocation – investing in growth, increasing shareholder returns</p>	<p>5</p> <p>A more sustainable business</p>
<p>Double-digit revenue growth at constant currency +11.1%</p> <p>Adjusted EBIT margin 7.4% +190 bps</p> <p>Adjusted Free Cash Flow €140.7 million</p>	<p>BEV bookings €1.3 billion</p> <p>HEV bookings €0.8 billion</p>	<p>New launches 48</p> <p>BEV bookings €0.4 billion</p>	<p>Acquisition of Cascade Engineering Europe €26 million</p> <p>Progressive dividend €35 million</p> <p>€40 million share buyback in progress</p>	<p>Scope 1 & 2 CO₂e reduction 15% versus 2021</p> <p>2030 targets SBTi approved</p>



On track

Revenue and Vehicle Production

FY 2023 year-on-year growth by region

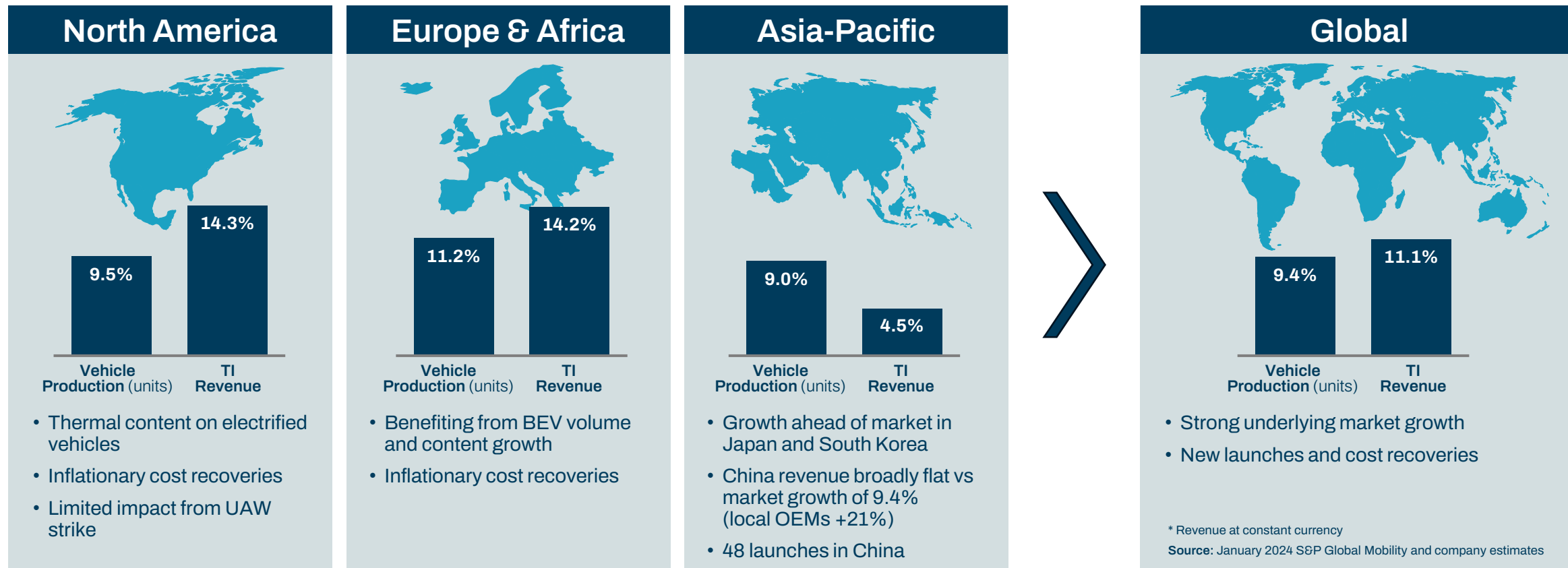

Benefiting from propulsion agnostic portfolio

02

Financial Performance



Alexander De Bock
Chief Financial Officer

Financial Highlights

Revenue

€3,516 million

+11.1% at constant currency

Adjusted EBIT

€259.6 million

+44.2%

Adjusted EPS

25.8 €cents

+56.8%

Adjusted Free Cash Flow

€140.7 million

+79.5%

ROCE

27.6%

+930bps

Net debt / Adjusted EBITDA

1.5 x

2022: 1.9 x

Strong performance across all key metrics

Revenue growth

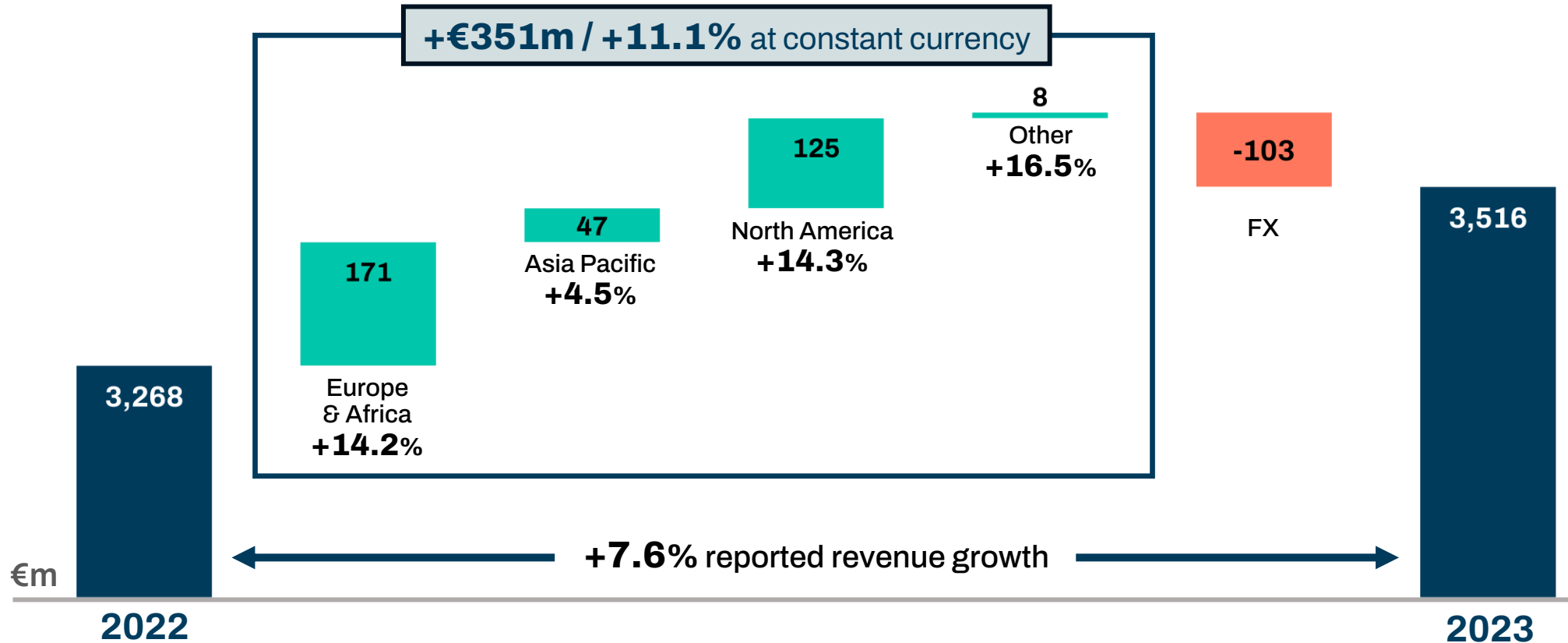

 Double-digit revenue growth at constant currency

Adjusted EBIT

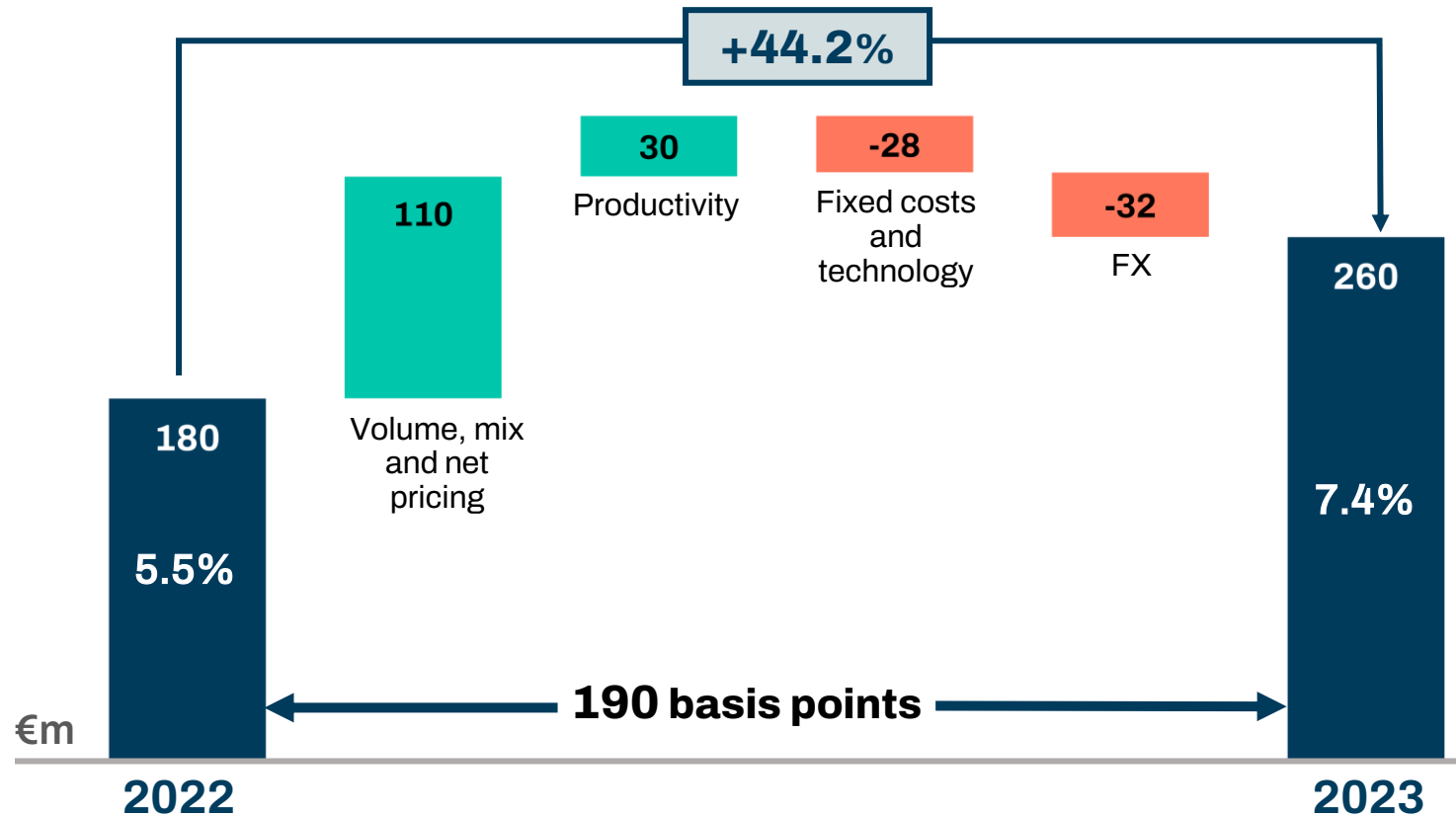

- Volume, mix and pricing net of inflation delivering €110m of incremental EBIT on €351m of revenue growth
- Efficiencies driven by operational improvements, restructuring and footprint optimisation
- Normalisation of fixed costs and investment in product development
- FX margin impact of (70)bps

Margin progress on track

Segment revenue and Adjusted EBIT margins TI Fluid Systems

Fluid Carrying Systems ('FCS')

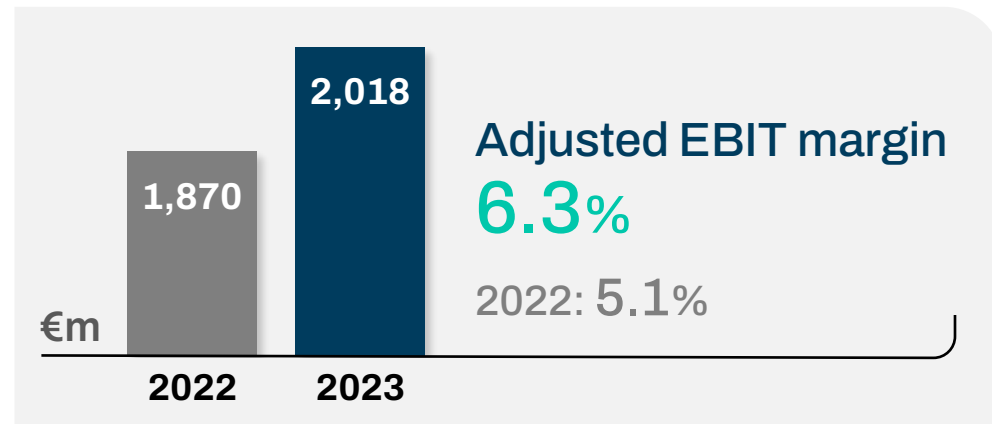

- 11.6% constant currency revenue growth
 - Thermal launches and ramp up on BEVs
 - Continued progress on HEVs
 - Inflationary cost recoveries
- Adjusted EBIT margin +120 bps
 - Productivity and cost recoveries
 - Temporary unfavourable effect from initial BEV launches
 - Investment in development and launch costs

Fuel Tank Delivery Systems ('FTDS')

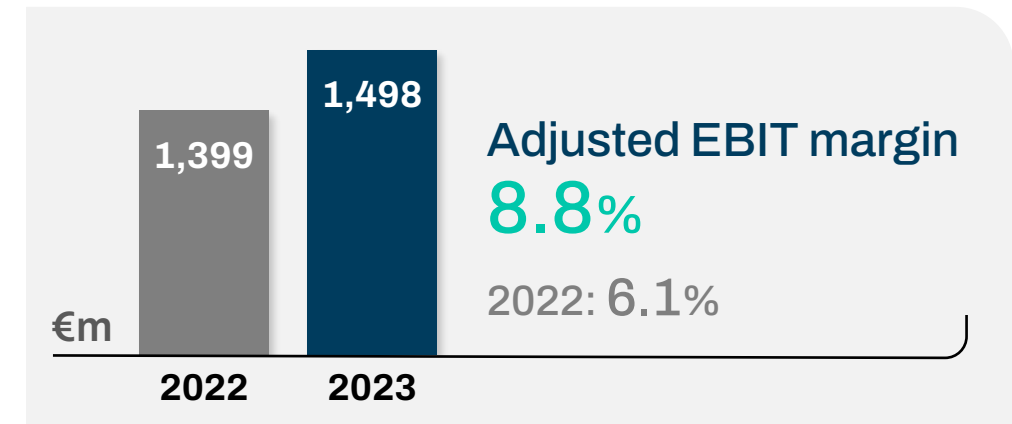

- 10.5% constant currency revenue growth
 - New launches in Europe, US, China
 - Ahead of market growth for ICE and HEV of 6.6%
 - Inflationary cost recoveries
- Adjusted EBIT margin +270 bps
 - Productivity and cost recoveries
 - Reducing investments

Adjusted Net Income & EPS

€m	FY 2023	FY 2022	y/y growth
Adjusted EBIT	260	180	+44%
Net Finance Expense	(75)	(59)	+27%
Adjusted Tax Charge	(52)	(37)	+41%
<i>Effective Tax rate</i>	28.1%	30.4%	(230)bps
Adjusted Net Income	133	84	+58%
Adjusted Basic EPS (€ cents / share)	25.8	16.4	+57%
Total Dividend (€ cents / share)	6.83	2.54	+169%

Adjusted EBIT increase of 44% translating into 57% increase in Adjusted EPS:

- Higher interest rates partially offset by €99.2m debt repayment
- Improved tax rate in-line with the average of the countries in which we operate

Adjusted EPS +57%

Adjusted Free Cash Flow

€m	FY 2023	FY 2022	y/y growth
Adjusted EBITDA	393	333	+18%
PP&E and Intangibles	(123)	(118)	+4%
Working Capital, Provisions and Other	1	(27)	
Cash Interest	(63)	(52)	+20%
Cash Tax	(67)	(58)	+14%
Adjusted Free Cash Flow	141	78	+79%
% of Adjusted EBITDA	36%	24%	
% of Adjusted Net Income	106%	93%	

- Converting €60m Adjusted EBITDA increase into €63m incremental Adjusted Free Cash Flow
- Maintaining PP&E investments at 3.5% while shifting investments from FTDS towards our thermal business
- Working capital ratio improving to 8.7% of sales (2022: 10.3%) driven by inventory and receivables management

Adjusted Free Cash Flow conversion 36%, ahead of target

Capital structure and leverage

Capital Structure

€m	Interest rate	FY 2023	FY 2022
Financial liabilities			
Secured Term Loan (2026)	SOFR + 3.25% Euribor +3.25%	425	537
Unsecured Senior Notes (2029)	Fixed at 3.75%	600	600
Unamortised Fees		(13)	(21)
Total borrowings		1,012	1,116
Cash and cash equivalents		(417)	(491)
Net Debt		595	625

Leverage Evolution (Net Debt / Adj. EBITDA)

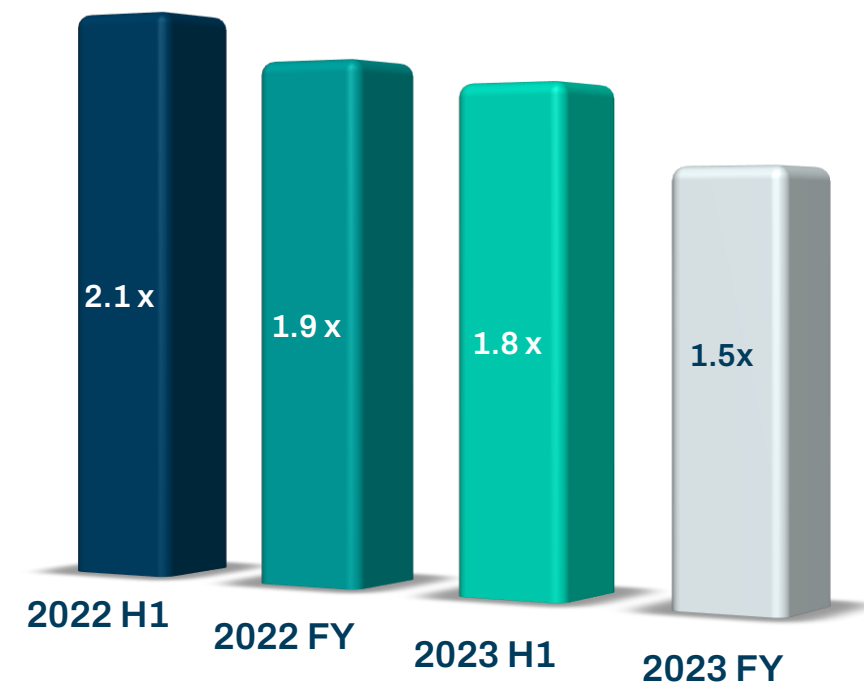

Strong balance sheet with net leverage reduced to 1.5x ahead of plan

Capital allocation

Capex / Capitalised R&D	Inorganic Growth	Dividends	Deleveraging	Share Buyback
Continue to invest 4-5% of revenue to support organic growth prioritising thermal	A key driver of value creation through technology and market share gains	Progressive growth Start at €35m for 2023	Term loan prepayment in H2 2023	Up to €40m starting in 2023
✓ 3.5% invested in 2023	✓ Cascade Engineering Europe	✓ Interim paid, final proposed	✓ Repaid €99.2m August	✓ 6.3m shares repurchased*

Targeting net leverage of ~ 1.5 x Adjusted EBITDA, retaining a strong financial position

* As at 8 March 2024



Delivering growth and shareholder returns

2024 market volume outlook

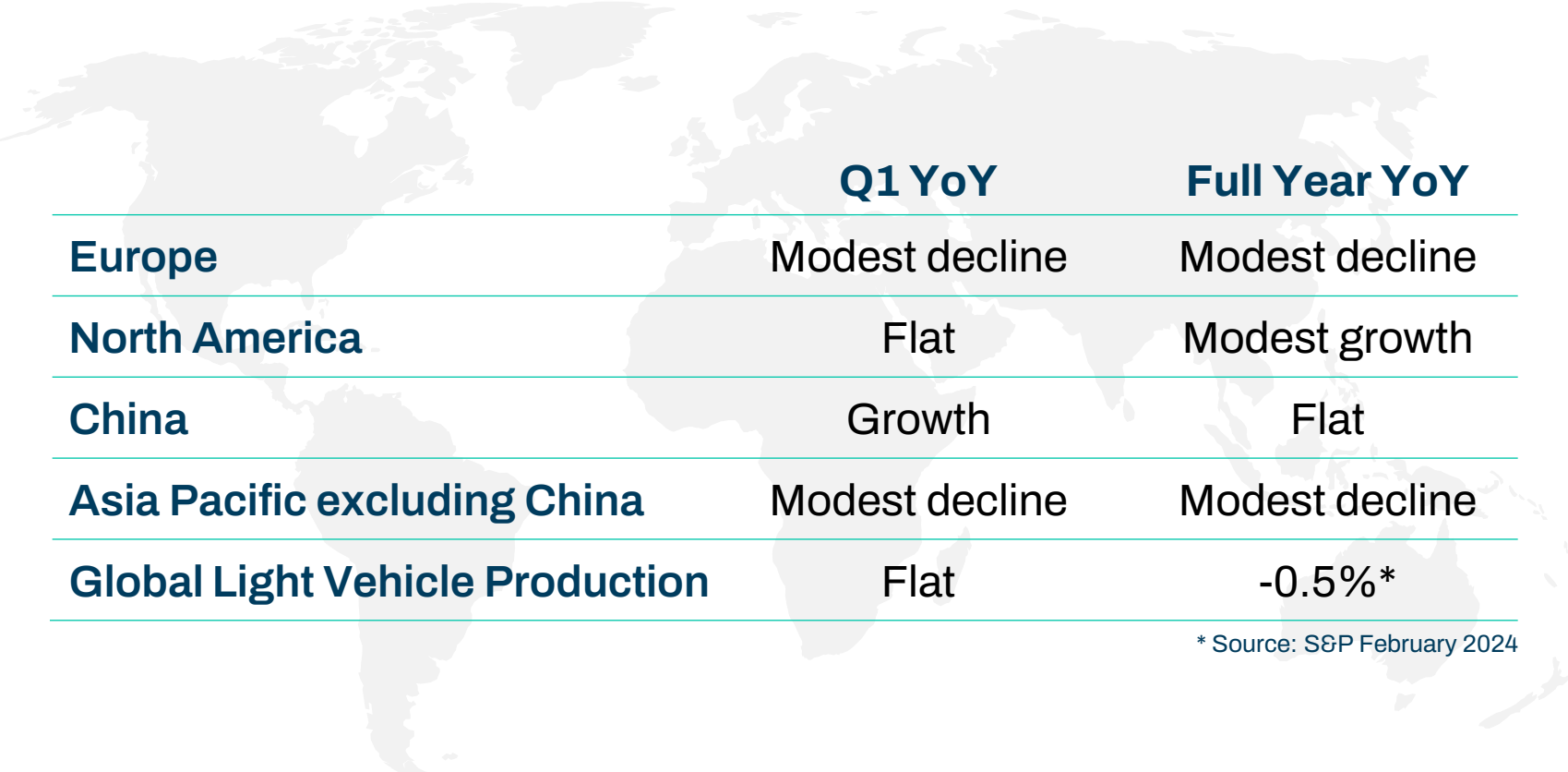

	Q1 YoY	Full Year YoY
Europe	Modest decline	Modest decline
North America	Flat	Modest growth
China	Growth	Flat
Asia Pacific excluding China	Modest decline	Modest decline
Global Light Vehicle Production	Flat	-0.5%*

* Source: S&P February 2024

Modest year-on-year industry volume decline

2024 progress towards a double-digit margin

Reconfirming CMD commitment

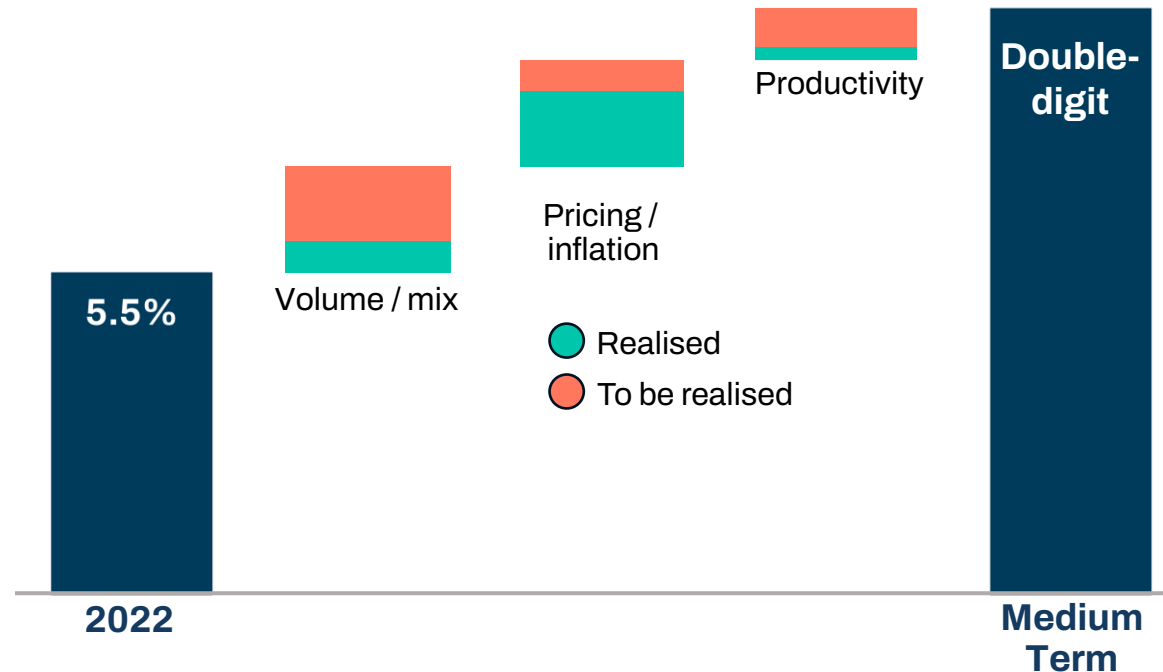

2024 focus on productivity

1

Continued footprint optimisation to adjust capacity and maintain cost competitiveness

- Benefits from 3 plants closed in 2023
- Plan to close 3 plants and downsize 5 in 2024

2

Operational efficiencies

- Recent launches in best cost countries
- Scrap reduction and labour efficiencies

3

Fixed cost optimisation

- Synergies and flexibility from regional structure
- ~4% fixed headcount reduction, ~70% implemented

4

Purchasing savings from localisation, supplier consolidation, economies of scale and lower inflation

5

More stable operating environment

Productivity to more than offset inflation and market volumes to drive 2024 margin expansion

2024 outlook

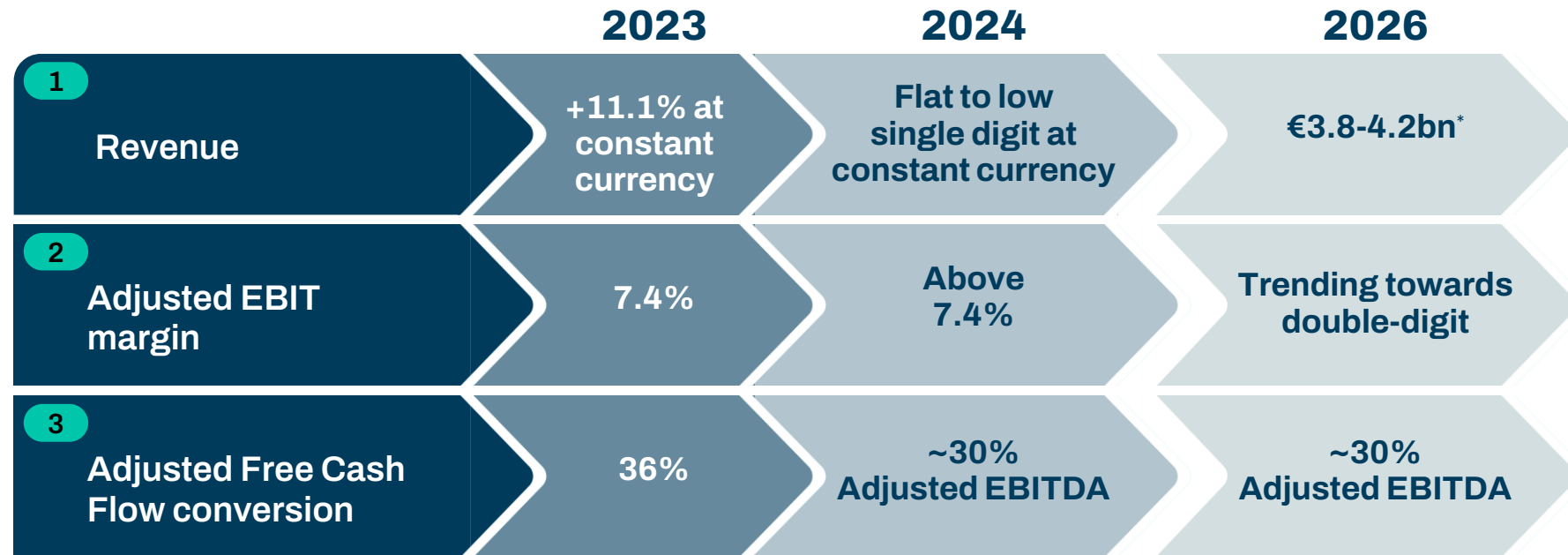

Other assumptions

- Foreign exchange ~(1)% of revenue at current exchange rates
- Interest costs €60-65 million
- Effective tax rate low 30%
- Capex 3-5% of revenue



Continued progress towards our mid-term targets

* Revenue target at constant currency, average 2022 foreign exchange rates

03

Strategic Progress

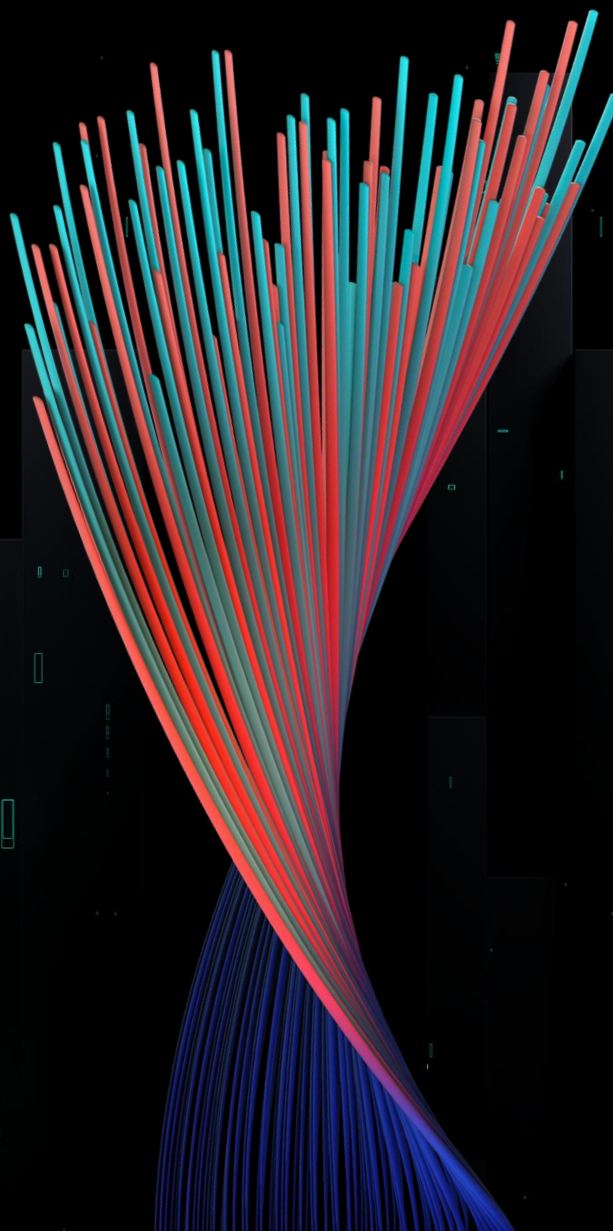

Hans Dieltjens
Chief Executive Officer & President

Taking the Turn

Capitalising on the **opportunities of electrification**

AND

Maximising the **strengths of our conventional portfolio**

	Strategic objectives	Targets
Revenue growth	<ul style="list-style-type: none"> Fluid handling for EVs Modules & Systems China Capitalise on conventional portfolio 	Revenue* <ul style="list-style-type: none"> By 2026: €3.8-4.2 billion* By 2030: >€4.5 billion
Return to double-digit adjusted EBIT margins	<ul style="list-style-type: none"> Convert volume growth Productivity & commercial effectiveness Transform ICE business 	Adjusted EBIT margin <ul style="list-style-type: none"> Mid-term: double-digit
Attractive shareholder value creation	<ul style="list-style-type: none"> Strong cash generation Maintain strong balance sheet Attractive shareholder returns 	<ul style="list-style-type: none"> 30% cash conversion Leverage 1.5x Progressive dividend
A more sustainable business	<ul style="list-style-type: none"> Emission reduction technologies People strategy Improving our operational footprint 	2030 emission reduction <ul style="list-style-type: none"> Scope 1 & 2: -50% Scope 3: -30%

Strategy for sustainable and profitable growth

* Revenue target at constant currency, average 2022 foreign exchange rates

Winning in electrification

Bookings € billion

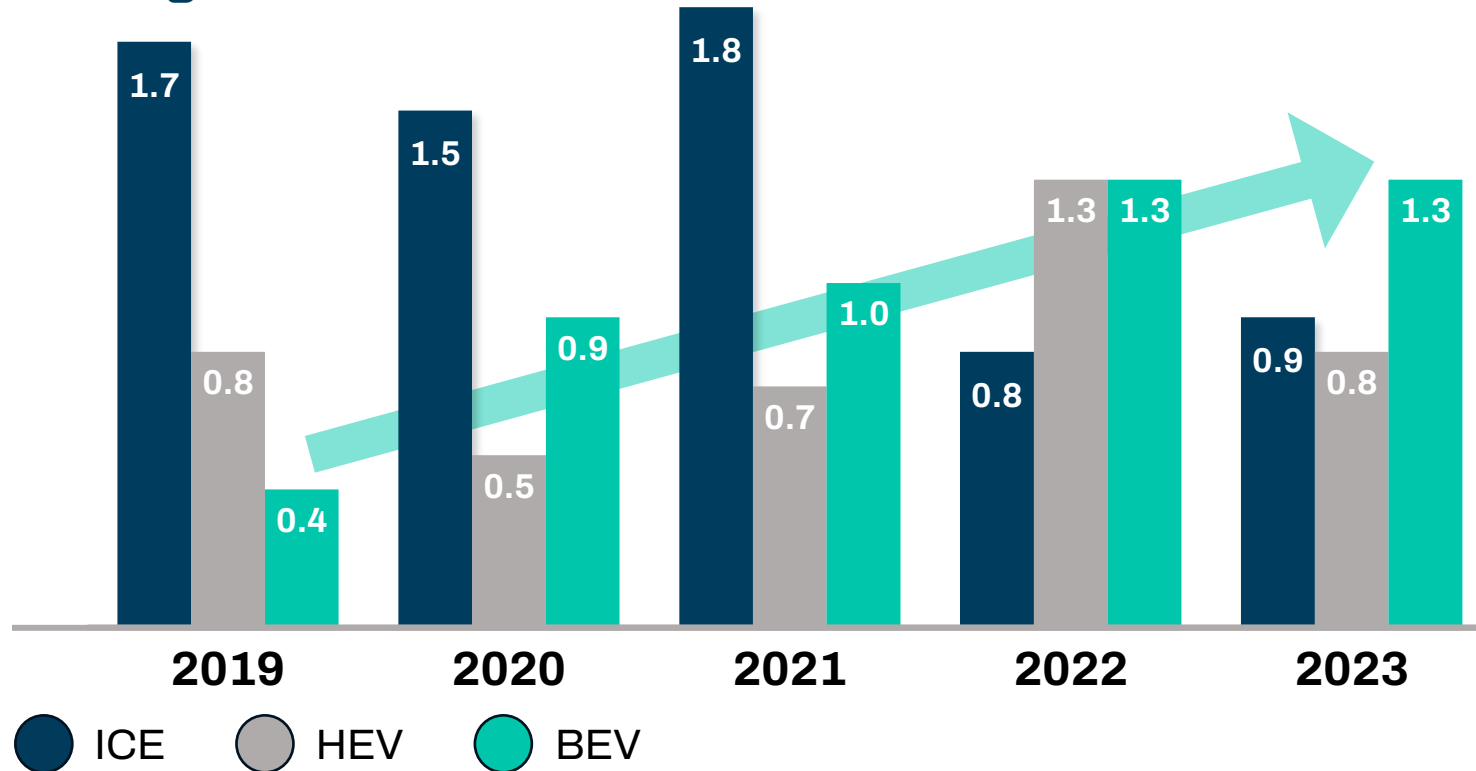

- BEV bookings remain strong
- Continued extensions of existing ICE platforms
- Strategic wins:
 - Modules & Systems
 - Local OEMs in China

Bookings support growth in fluid handling for EVs

Key launches in H2 2023

HEV 



Mercedes-Benz E Class
Thermal Refrigerant
Lifetime revenue: **€35m**

BEV 



Geely Lotus E-Sedan
Thermal Coolant Lines
Lifetime revenue: **€9m**

BEV 



FAW Hongqi
Thermal Refrigerant & A/C Lines
Lifetime revenue: **€3m**

BEV 



Volkswagen ID.7
Thermal Coolant lines
Lifetime revenue: **€64m**

BEV 



Rivian RS1/RT1
Thermal Refrigerant & Brake lines
Lifetime revenue: **€73m**

HEV 



Toyota C-HR
Fuel Tank
Lifetime revenue: **€75m**

PHEV/HEV 



Stellantis eVMP
Fuel Delivery Module
Lifetime revenue: **€50m**

Growing our EV revenues

Further strengthening thermal offering for EVs TI Fluid Systems

TIFS technology innovation

Electric coolant pump

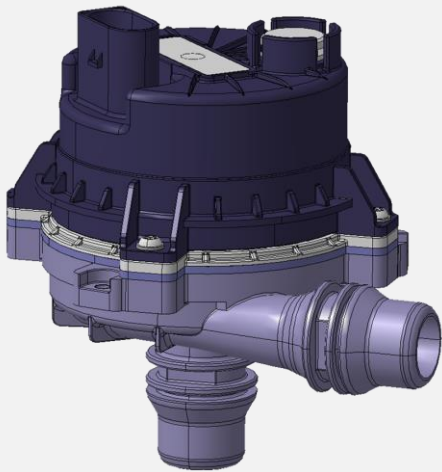

Electric coolant valve

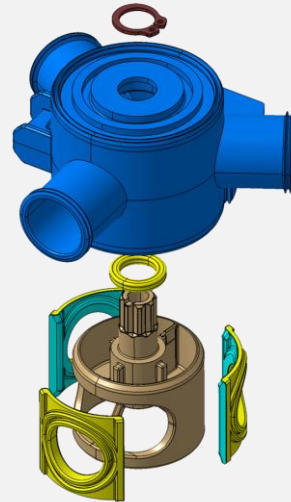

Strategic collaboration with Sanden



Market-leading Thermal Management capability



Leading supplier of e-compressors

Completing our product portfolio for thermal Modules & Systems

China

Market – 2023 light vehicle production +9.4%

- Local OEMs +21% versus global OEMs -4%

Enhancing our position with local OEMs in 2023

- 400 bps increase in share of revenue from local OEMs
- 48 launches, over half with local OEMs
- Half of our bookings with local OEMs
- Strategic awards with largest local OEM and first Module award
- 81 launches planned for 2024

Mid-term outlook – 2028 target revenue €1-1.2 billion

- >70% of 2026 revenue booked
- 30-40% of 2026 revenue expected to be from local OEMs



eMIC opened in Jiading in October



Enhancing our position in an important market

2023 progress on sustainability

Greener products for cleaner vehicles

€1.3 billion
BEV bookings



€124 million
Capex and R&D focused on thermal products for EVs

Innovation

Products with lower emissions production processes



Reducing emissions in a growing business

-15%
Scope 1 & 2 emissions



SBTi approved 2030 targets*

- Scope 1 & 2: -50%
- Scope 3: -30%

2030 waste targets

- 90% landfill avoidance
- 80% recycling rate



* Targets versus 2021 baseline

People

3.0
Lost time injury frequency rate



Health & Safety culture

Expanded global safety management system to an additional 27 sites

Women in STEM
43 scholarships



* Employee, contractor & visitor lost time injury frequency

Greener technologies, cleaner vehicles, a sustainable future

Confident in mid-term targets

**2026
revenue**

€3.8- €4.2 billion*

**Mid-term
Adjusted EBIT margin**

**Return to
double-digits**

**Adjusted Free Cash Flow
conversion**

**~30% of
Adjusted EBITDA**

* Revenue target at constant currency,
average 2022 foreign exchange rates

Continued progress towards our mid-term targets in 2024

Q&A

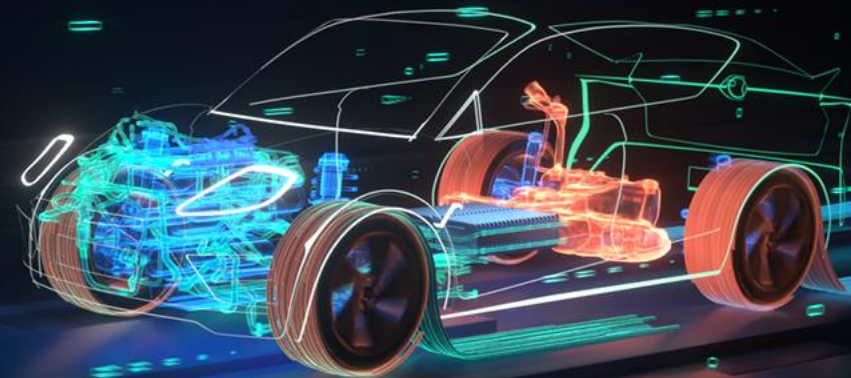

Investment Proposition

- ① **Leading market positions** rooted in innovation, diverse automotive customer base and global presence
- ② **Clear strategy** to drive growth and capitalise on the electrification transition
- ③ On track to return to **double-digit margins** with strong cash conversion
- ④ **Capital allocation** focused on short- and long-term shareholder value creation while maintaining a strong balance sheet
- ⑤ **Clear ESG strategy** and implementation commitment with activities on track

Appendix



Reconciliation of Adjusted EBITDA / EBIT to statutory measures

€m	FY 2023	FY 2022
Revenue	3,516.2	3,268.3
Adjusted EBIT	259.6	180.0
<i>Adjusted EBIT %</i>	<i>7.4%</i>	<i>5.5%</i>
D&A (excluding PPA)	133.4	153.3
Adjusted EBITDA	393.0	333.3
<i>Adjusted EBITDA %</i>	<i>11.2%</i>	<i>10.2%</i>
D&A	(178.9)	(207.6)
Exceptional impairment	-	(317.4)
Net FX Losses	(0.2)	(0.7)
Net restructuring costs	(13.4)	(22.8)
Other reconciling items	(4.7)	(1.8)
Operating profit / (loss)	195.8	(217.0)
Net finance expense	(74.7)	(58.7)
Tax	(37.5)	(3.3)
Profit / (loss) for the year	83.6	(279.0)

- **Adjustments** primarily relate to certain non-operational and non-cash expenses
- **Purchase Price Accounting (PPA)** depreciation and amortisation arising on the fair value uplifts related to the Bain Capital, Millennium and Cascade acquisitions

Income Tax Charge

€m	FY 2023			FY 2022		
	PBT	Charge	ETR	PBT	Charge	ETR
Result excluding adjusting items						
Tax charges – recognised	220.8	(52.0)	23.6%	164.8	(36.9)	22.4%
Tax losses – not recognised (mainly UK)	(35.9)	-	-	(43.5)	-	-
Result excluding Adjusting items	184.9	(52.0)	28.1%	121.3	(36.9)	30.4%
Adjusting items exc. Impairment	(63.8)	14.5	22.7%	(79.6)	13.5	17.0%
Reported result before exceptional items	121.1	(37.5)	31.0%	41.7	(23.4)	56.1%

The effective tax rates are impacted by:

- Increase in the level of taxable profit
- UK book loss of €35.9m that is not tax affected due to historical and projected UK loss position

Adjusted Net Income, Adjusted Basic EPS

€m	FY 2023	FY 2022
Profit / (loss) for the year	83.6	(279.0)
Restructuring	13.4	22.8
Exceptional impairment charge	-	317.4
Purchase accounting D&A	45.5	54.3
Other	4.8	2.4
Tax on adjusting items	(14.5)	(33.6)
Adjusted Net Income*	132.8	84.3
Adjusted Basic EPS (€cents / share)	25.76	16.43

*Adjusted Net Income and Adjusted EPS definition updated to include an adjustment for depreciation and amortisation arising on purchase accounting, net of tax, consistent with the Group's definition of Adjusted EBIT.

Return on Capital Employed

€m	FY 2023	FY 2022
Adjusted EBIT	259.6	180.0
Capital employed		
Total equity	665.8	676.7
Net current and deferred tax (assets)/liabilities	(21.0)	12.1
Derivative financial instruments	(2.9)	(2.6)
Net debt and lease liabilities	727.5	774.5
Restructuring provisions	4.6	7.8
Purchase price allocation balances arising on the Bain acquisition	(448.7)	(510.9)
Capital employed	925.3	957.6
Average capital employed	941.5	983.8
Return on Capital Employed	27.6%	18.3%

Adjusted Net Income & Adjusted EPS

Reconciliation from previous reports

	2018	2019	2020	2021	2022
Adjusted Net Income (€m)					
Previous basis	155	150	14	58	44
Purchase accounting D&A	86	73	56	52	54
Tax impact of adjusting items	(21)	(18)	(14)	(12)	(14)
New basis	220	205	56	98	84
Adjusted Basic EPS (€ cents / share)					
Previous basis	29.87	28.91	2.64	11.23	8.48
New basis	42.44	39.39	10.68	18.78	16.43
Shares (m)	519.5	519.9	519.8	519.1	513.1

Adjusted Net Income definition updated at H1 2023 to exclude purchase price accounting items, consistent with other adjusted performance measures

Glossary of terms

Adjusting Items - Adjusting items represent transactions that in Management's view do not form part of the substance of the trading activities of the Group, such as large-scale reorganisations, system implementations, acquisition costs and certain non-cash accounting measures. At the reporting date, Adjusting Items comprise: depreciation and amortisation arising on purchase accounting, net foreign exchange losses/(gains), restructuring costs, customisation and configuration costs of significant software as a service ("SaaS") arrangements and costs associated with business acquisitions or disposals.

Adjusted Basic EPS - Adjusted Net Income divided by the weighted average number of shares in issue in the period

Adjusted EBIT - Operating profit excluding Adjusting Items.

Adjusted EBITDA - Adjusted EBIT plus depreciation, amortisation and non-exceptional impairments on non-purchase accounting.

Adjusted Free Cash Flow - Free Cash Flow adjusted for cash movements in financial assets at fair value through Profit or Loss, and the net cash flows arising on Adjusting Items.

Adjusted Net Income - Profit or Loss for the period attributable to ordinary shareholders, excluding Adjusting Items, net of their tax effect.

BEV – Battery electric vehicles

Constant currency - The remeasurement of prior period results at current exchange rates to eliminate fluctuations in translation rates and achieve a like-for-like comparison.

FCS - Fluid Carrying Systems, a division of the Group which supplies Brake & Fuel lines and thermal products.

FTDS - Fuel Tanks and Delivery Systems, a division of the Group that supplies fuel tanks and fuel pumps and modules.

GLVP - Global Light Vehicle Production of light vehicles.

HEV - Hybrid Electric Vehicles, excluding mild hybrid vehicles.

ICE - Internal Combustion Engine vehicles.

ITMa – Integrated Thermal Manifold

Net debt - The total of current and non-current borrowings excluding lease liabilities, net of cash and cash equivalents and financial assets at fair value through profit or loss.

Net leverage - Net debt divided by last 12 months' Adjusted EBITDA.

OEM - Original Equipment Manufacturer, used to refer to vehicle manufacturers the main customers of the Group.

NEV – New Energy Vehicle

PHEV - Plug in Hybrid electric vehicles

Revenue outperformance - The growth in revenue at constant currency compared to the growth in light vehicle production volumes.

Return on Capital Employed - Adjusted EBIT divided by the two-year trailing average of capital employed, which is defined as total equity, excluding taxation balances, derivatives, net debt and lease liabilities, restructuring provisions and balances related to Bain acquisition accounting (goodwill, intangible assets and purchase price allocation adjustments).

SBTi - Science-Based Target Initiative which is used to refer to the climate change targets aligned to the Paris Agreement targets.